

# automatic gain control circuits

Automatic gain control (AGC) circuits, are used in receivers to maintain the output signal level constant regardless of changes in input signal strength, such as are caused by fading and other atmospheric conditions. Essentially, an AGC circuit receives a sinusoidal input signal, such as an AM wave, and delivers a d-c output signal whose amplitude is proportional to the amplitude of the input signal. The d-c output is usually a *negative* voltage, but in transistorized equipment, it can be positive. So, the greater the amplitude of the a-c input signal, the larger the d-c output. Conversely, the smaller the amplitude of the a-c input, the smaller the d-c output.

An important characteristic of an AGC circuit is that it does not respond to *instantaneous* amplitude variations of the a-c input signal. If it did, it would respond to the intelligence-carrying amplitude variations of an AM signal. Instead, the AGC circuit delivers its d-c output in accordance with *slower*, average amplitude variations of the input signal, which occur with changing signal strengths, such as those caused by atmospheric fading.

AVC and AGC circuits deliver negative d-c output signals whose amplitudes vary in accordance with the slow average amplitude variations of the sinusoidal input signals

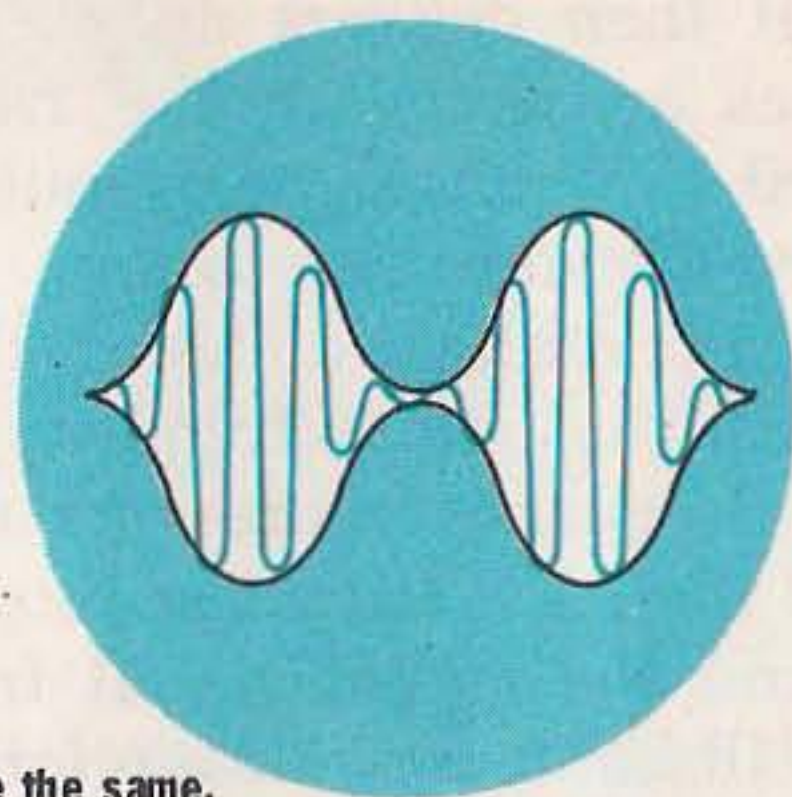
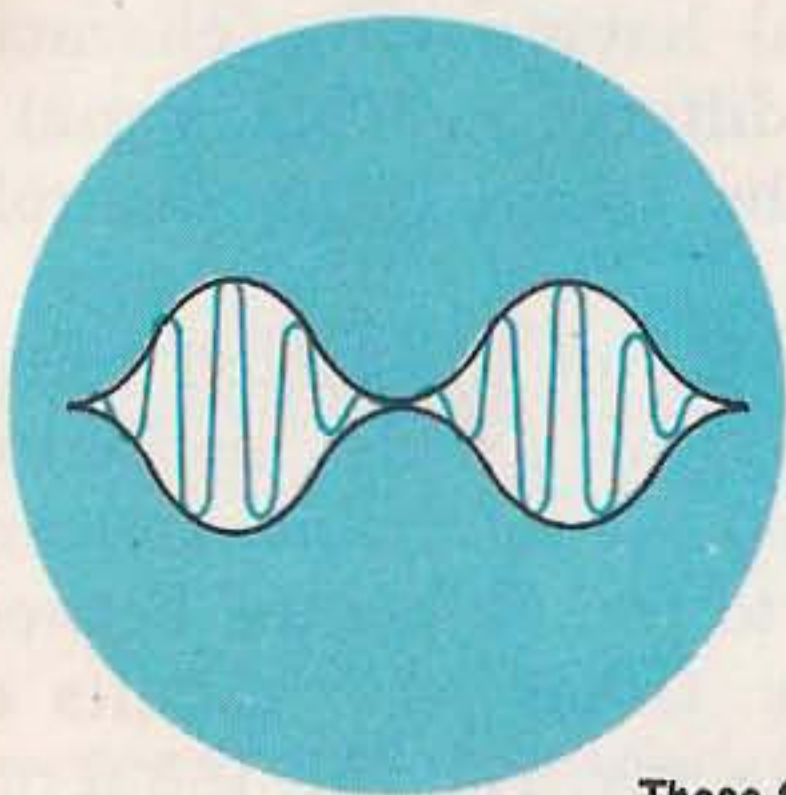
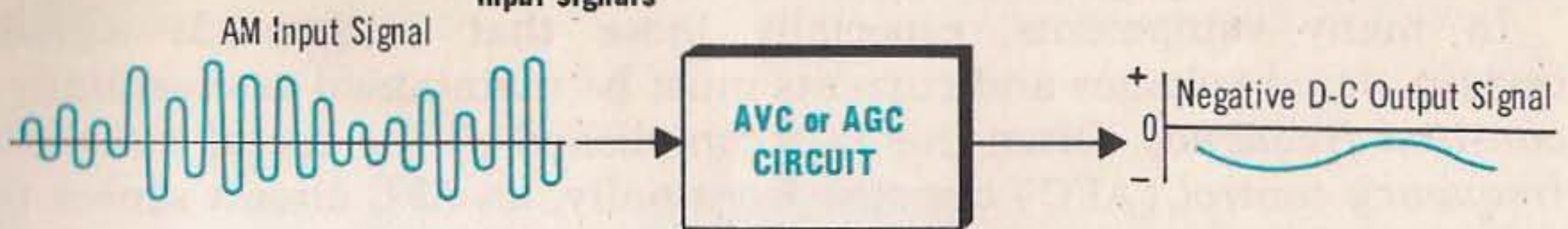

These two signals are the same, except that the one on the right is stronger, and so will produce a greater AGC voltage

AGC circuits are also called *automatic volume control (AVC) circuits*. Whether these circuits are designated AVC or AGC usually depends on where and in what equipment they are used. This will be explained more fully later.

# AVC and AGC circuits

In previous volumes, you learned about volume control and gain control circuits. In their simplest form, these are usually variable resistors that control either the gain or the input or output signal amplitude of an amplifier. The volume control of a radio receiver is the most common example of a volume or gain control. By *manually* adjusting such a control, the desired output level is obtained.

A disadvantage of manual gain control with a receiver is that it cannot provide a *constant* output under all conditions. If a receiver is tuned from a weak signal to a strong signal, its output might increase to an intolerable level. This would then require readjustment of the volume control. Similarly, when a receiver is tuned to a particular signal, the output level can vary widely if the input signal strength fluctuates as a result of fading and other similar transmission phenomena. Under such conditions, constant readjustment of the volume control would be necessary. This is obviously impractical, since such signal fluctuations are *rapid*.

To overcome these problems, *automatic volume control* (AVC) or *automatic gain control* (AGC) is frequently used in addition to the manual control. The manual control initially sets the receiver output at the desired level. The AGC circuit then automatically keeps the receiver output at this level in spite of variations in the input signal strength.

AVC and AGC circuits automatically compensate for undesirable variations in signal strength and thus maintain a relatively constant output level

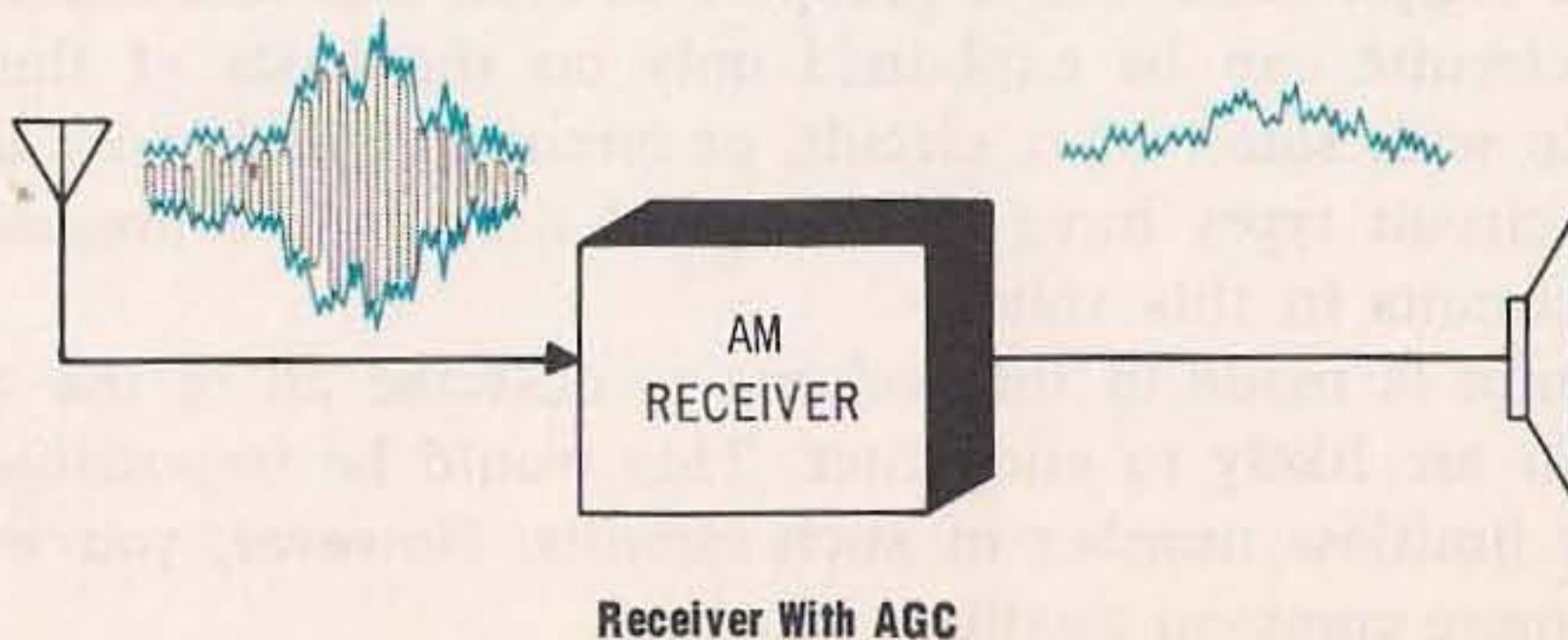
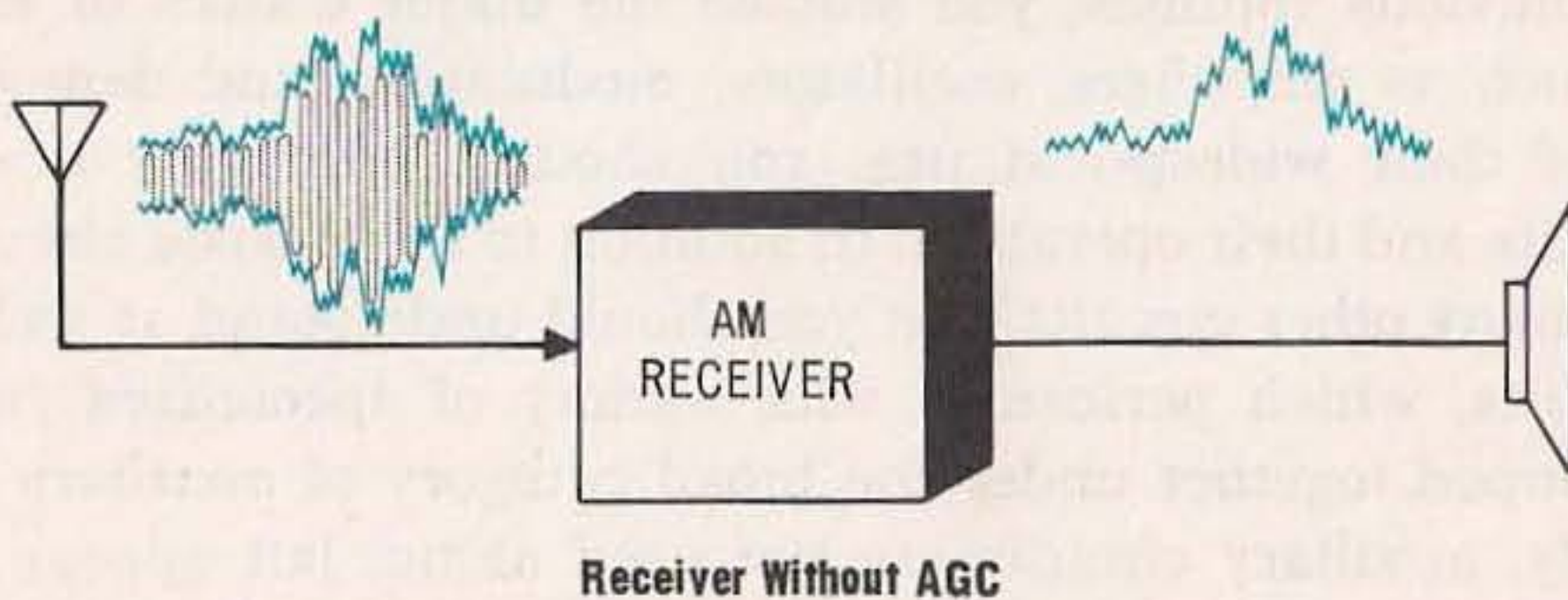

# basic principles of AVC and AGC circuits

All AGC (and AVC) circuits perform two basic functions. The first of these is to develop a d-c voltage that is proportional to the receiver input signal strength at all times. This AGC voltage, as it is called, increases when the received signal strength increases and decreases when the signal strength decreases. The second function of the AGC circuit is to apply the AGC voltage to the r-f and i-f stages of the receiver, where it serves as a bias voltage. In this way, the AGC voltage controls the gain of the r-f and i-f stages, and, therefore, the overall gain of the receiver.

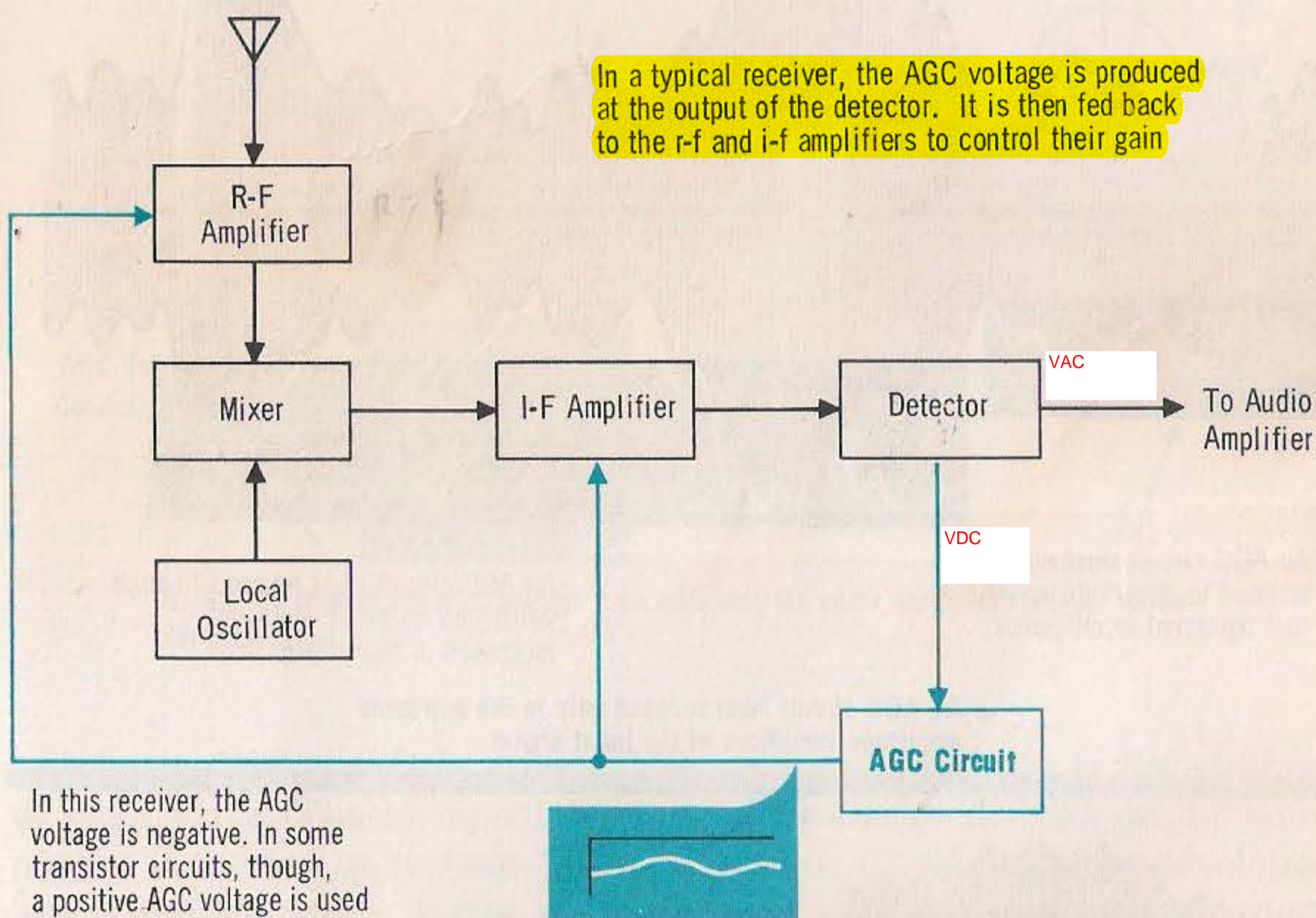

In a typical receiver, the AGC voltage is produced at the output of the detector. It is then fed back to the r-f and i-f amplifiers to control their gain

In this receiver, the AGC voltage is negative. In some transistor circuits, though, a positive AGC voltage is used because of the bias polarity needed by the transistor

When the signal level at the receiver input increases, the AGC voltage increases a proportionate amount. Consequently, a larger bias is applied to the r-f and i-f stages, and their gain is reduced. The receiver output thus remains relatively constant, instead of increasing in accordance with the input signal strength.

When the receiver input signal decreases in strength, the opposite action occurs. The AGC voltage drops in amplitude, the bias of the r-f and i-f stages is reduced, and the receiver gain increases. Again, the receiver output level remains essentially constant.

# response of AGC circuits

An AGC circuit must produce a d-c voltage that varies in amplitude in accordance with the signal strength variations caused by fading and other atmospheric conditions. However, the AGC circuit must not respond to the amplitude variations of the input signal that represent intelligence. If it did, the AGC voltage would tend to counteract the modulation envelope of the r-f carrier. This, of course, would result in distortion of the signal.

RECEIVER INPUT SIGNAL

Amplitude Modulation Envelope

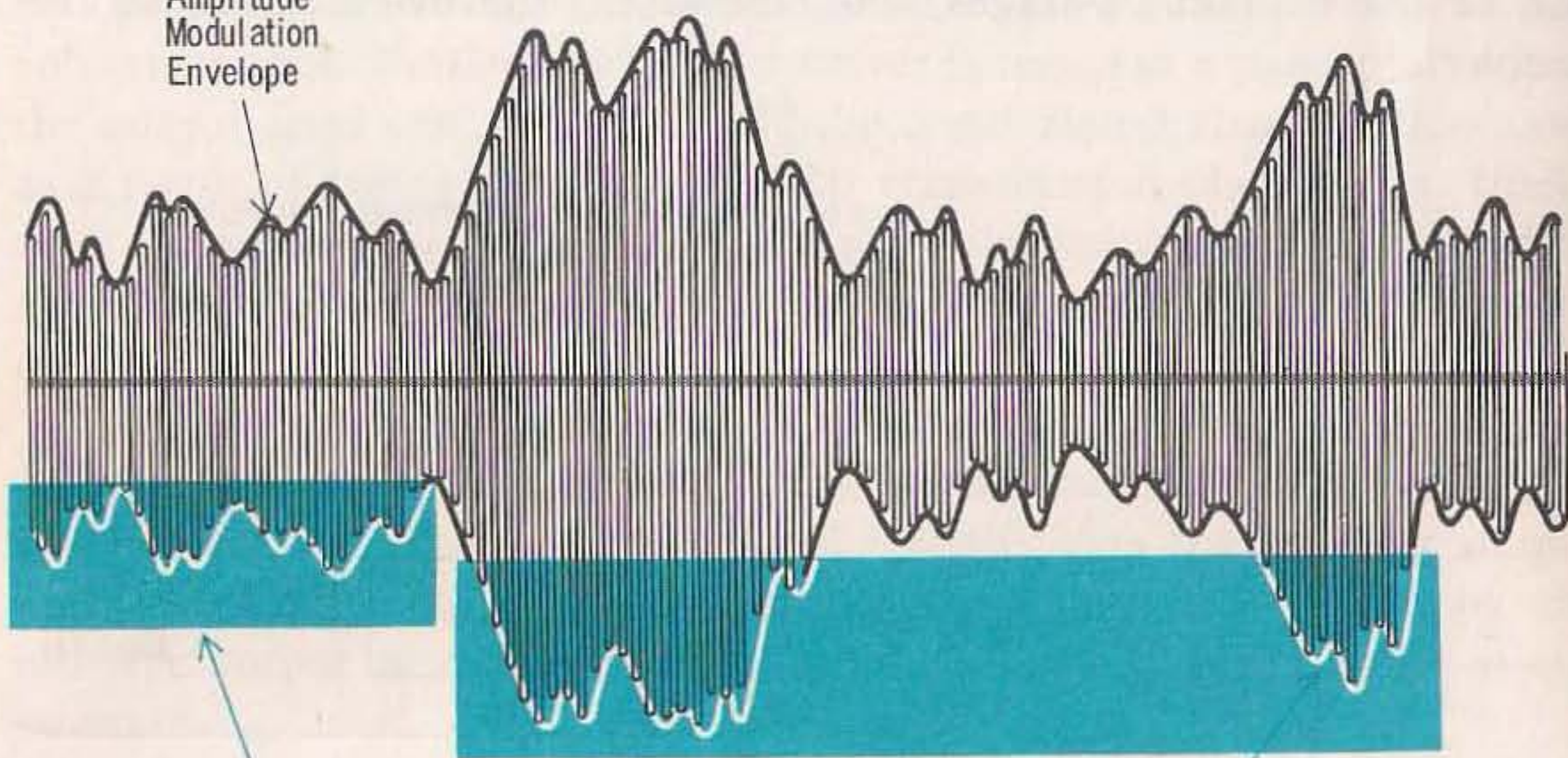

An AGC circuit must not respond to amplitude variations that represent intelligence

An AGC circuit must respond to such variations as these unwanted increases in signal amplitude

An AGC circuit must respond only to the unwanted amplitude variations of the input signal

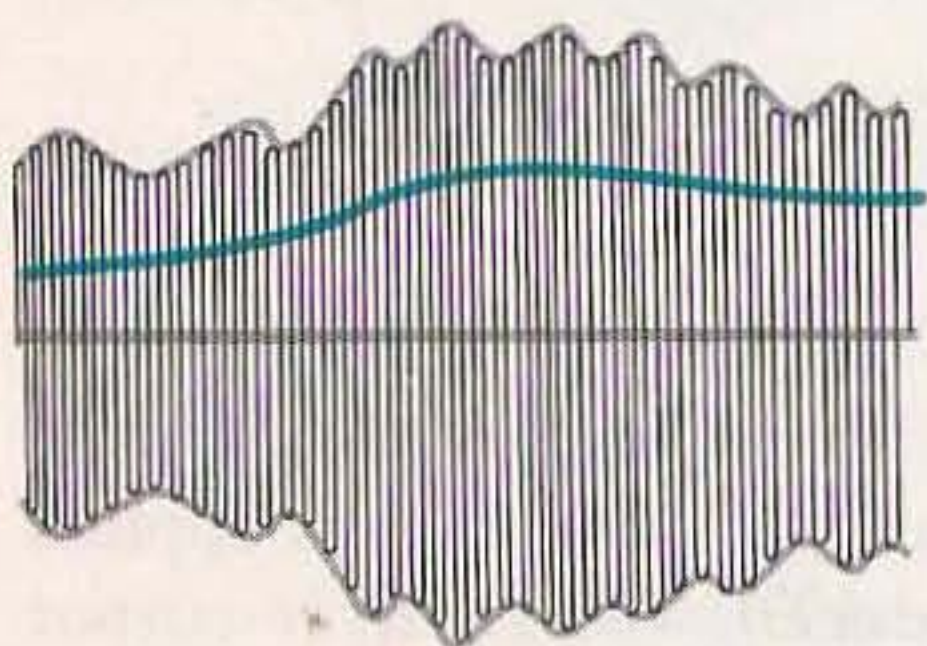

This diagram shows how the average level of the positive alternations varies with signal strength. This is the variation that produces the AGC voltage

The amplitude variations in a receiver input signal that are caused by fading are considerably *slower* than the amplitude variations that correspond to intelligence. So an AGC circuit must respond to relatively low-frequency amplitude variations, but not to high-frequency variations that represent intelligence.

# the basic AGC circuit

In a receiver, the most convenient place to derive an AGC voltage is from the output of the detector stage. This is because the detector produces a fluctuating d-c output voltage that varies in proportion to the receiver input signal strength. The a-c component of the detector output serves as the receiver audio signal (or the video signal in a television receiver). But the d-c component, when properly filtered, is highly suitable as an AGC voltage.

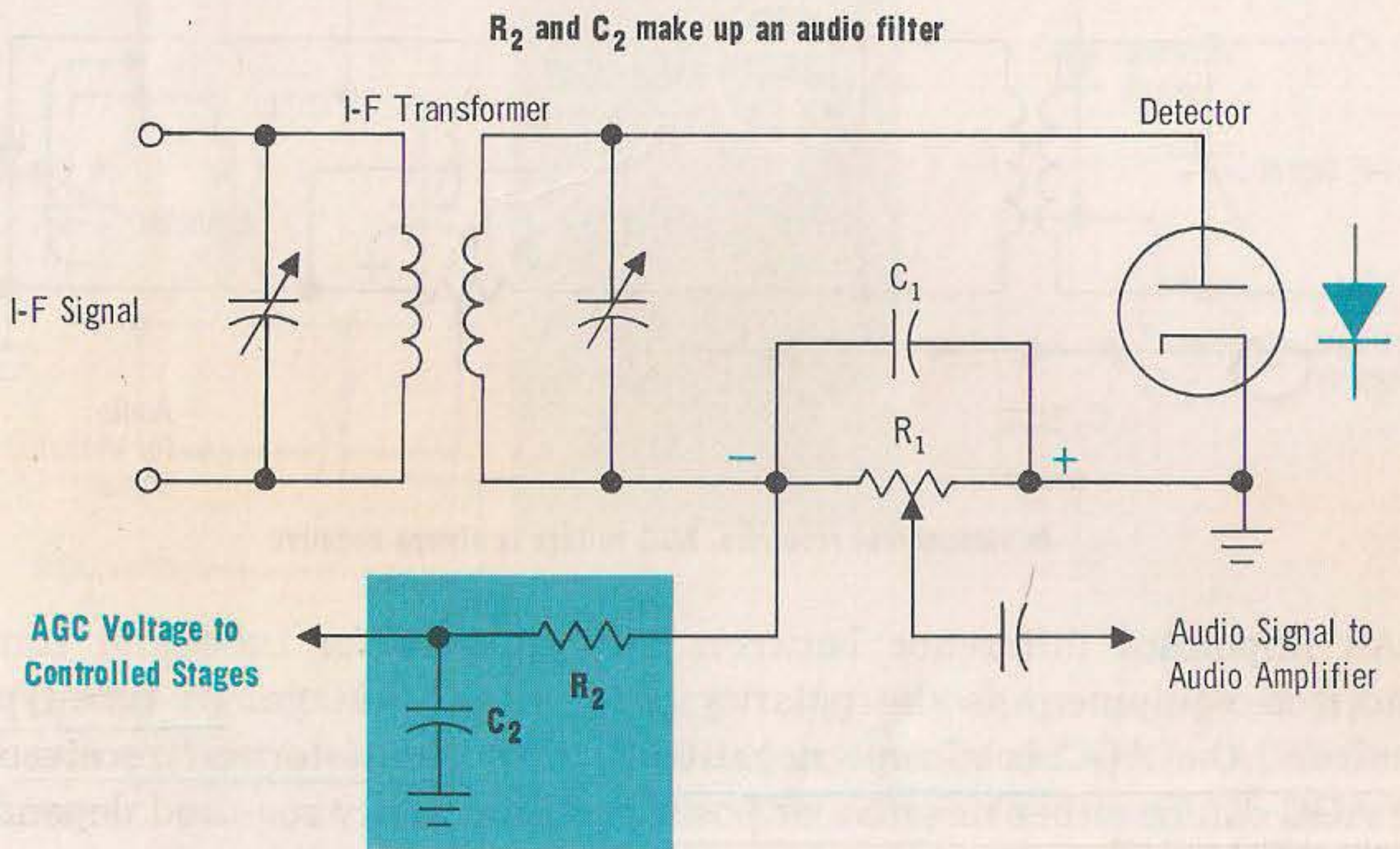

$R_2$  and  $C_2$  prevent the AGC voltage from following the audio variations present in the detector output signal

A basic AGC circuit is shown. The vacuum-tube diode is the receiver detector stage. The i-f signal is rectified by the diode and the i-f component is filtered by resistor  $R_1$  and capacitor  $C_1$ . The voltage developed across  $R_1$ , therefore, varies in accordance with the audio modulation. However, its average d-c amplitude also changes in proportion to changes in the input signal strength. Resistor  $R_2$  and capacitor  $C_2$  remove the audio component from the voltage across  $R_1$ , leaving only the d-c component, which is the AGC voltage. The AGC voltage is then applied to the r-f and i-f amplifiers to control their gain. Usually, the AGC voltage is carried on a common wire, or line, called the AGC bus.

The AGC voltage shown is *negative*, since it is taken from the ungrounded side of resistor  $R_1$ . In tube-type receivers, the AGC voltage is always negative, since it must vary the negative bias on the grids of the controlled tubes. With transistor circuits that require a positive AGC voltage, the diode detector is reversed.

# positive AGC

In transistorized receivers, semiconductor diodes are normally used as detectors. An AGC voltage can be derived from such detectors in exactly the same manner that it is derived from electron-tube detectors. This can be seen by comparing the circuit shown in A with that shown on the previous page. The only difference is that one uses a semiconductor diode and the other uses an electron-tube diode.

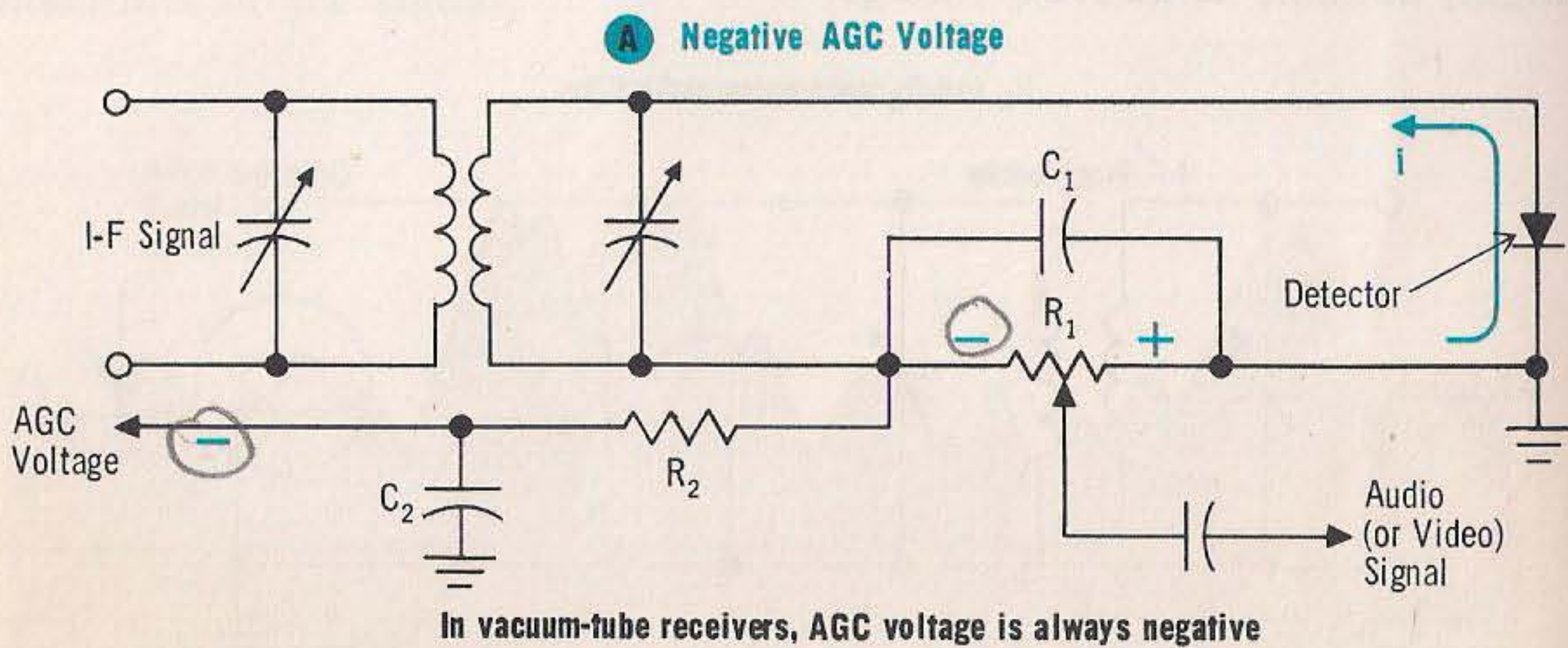

An important difference between AGC circuits for tube and transistorized equipment is the polarity of the AGC voltage. In tube-type receivers, the AGC is always negative. But in transistorized receivers, the AGC can be either negative or positive. The polarity required depends on the type of transistors and the circuit configuration used for the r-f and i-f amplifiers. Generally, the same circuit can produce *either* a negative or a positive AGC voltage. The only difference is the point at which the voltage is taken from the detector circuit, or the diode polarity used. As an example, the circuit shown in A can be made to produce a positive AGC voltage by reversing the diode. The AGC voltage is then taken from the positive side of resistor  $R_1$ . This is shown in B.

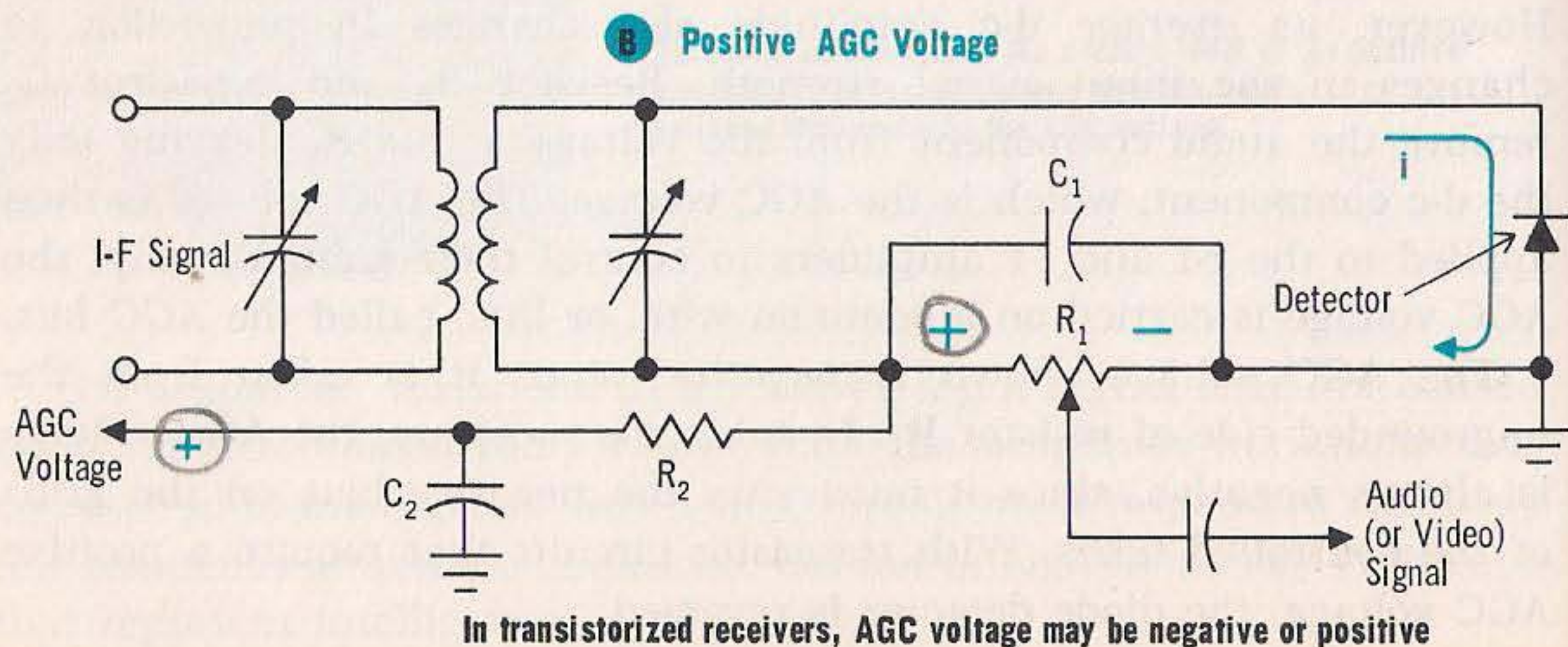

# Other AGC Circuits

Many variations of the basic AGC circuit just described are frequently used. All of them, however, are essentially similar. Sometimes, a *separate* diode is used for the AGC circuit. Such a circuit is shown in A. The AGC diode is used only to produce the AGC voltage. It does not serve as the detector stage for the receiver.

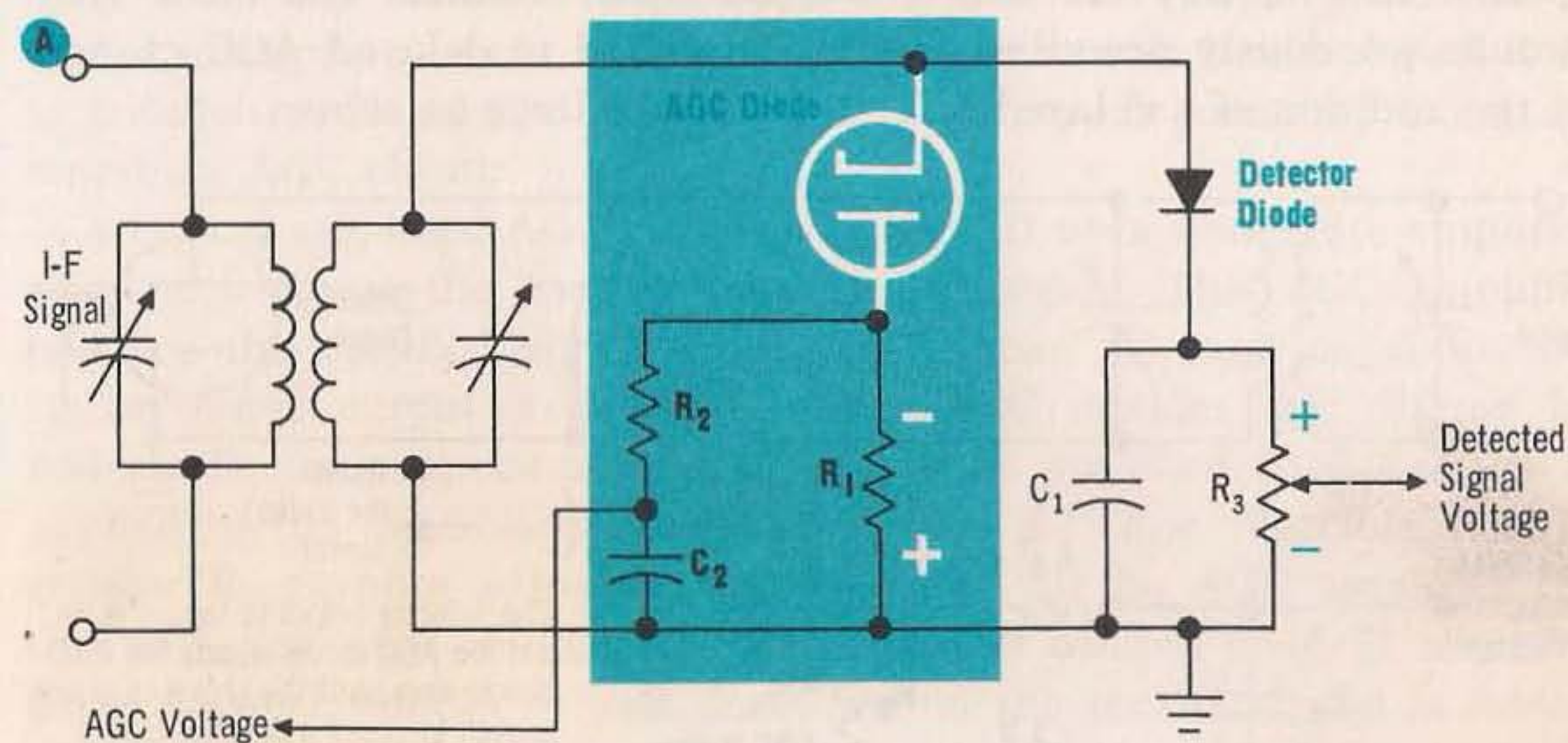

In the circuit shown, the detected signal voltage produced by the detector diode is *positive*. The AGC voltage produced by the AGC diode, however, is *negative*, since its plate is returned to ground. Resistor  $R_2$  and capacitor  $C_2$  filter the rectified i-f signal to produce a steady d-c voltage for the AGC. This type of circuit is used in receivers in which the output of the detector must be positive, although a negative AGC is needed.

Frequently, a single tube is used as an amplifier, a detector, triode and an AGC rectifier (as shown in B). These tubes contain small, subsidiary plates in addition to the regular plate. The small plates are used for the AGC circuit and the detector. Using a separate AGC diode minimizes the *interaction* between the detector and AGC circuits. This tube is a duo-diode triode.

## B Duo-Diode Triode

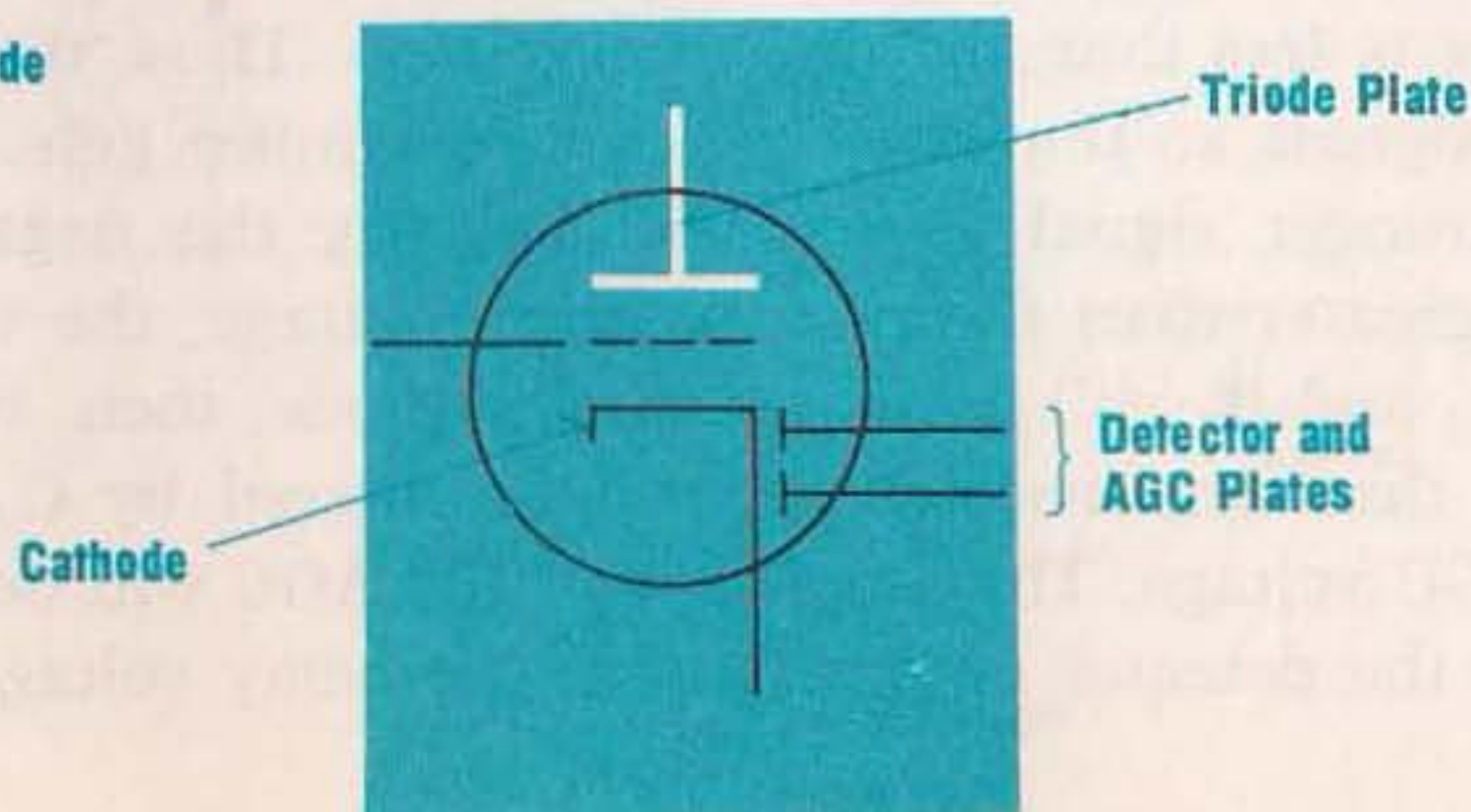

# delayed AGC

The disadvantage of simple AGC is that it reduces the gain of even very *weak* input signals. This is undesirable, since weak signals require as much gain as possible. Ideally, therefore, an AGC circuit should produce *no* AGC voltage for weak signals, but function normally when the input signal rises above some certain minimum level. Circuits that operate in this way are called *delayed AGC* circuits. The basic AGC circuits previously described can be converted to delayed AGC circuits by the addition of a delayed AGC diode and voltage as shown.

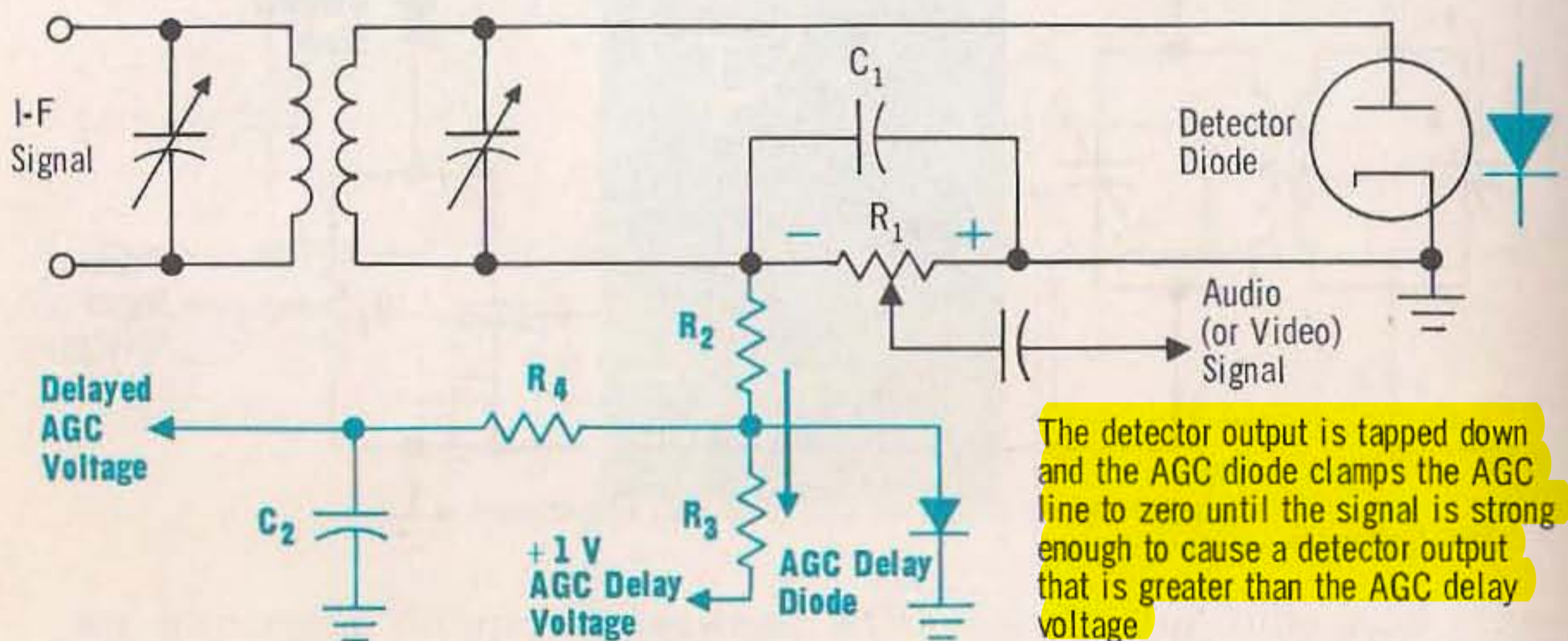

Resistors  $R_2$  and  $R_3$  are connected between the anode detector output and the delay voltage to control the delay diode.  $R_2$  and  $R_3$  are *equal* and drop equal voltages. When the d-c output of the detector is  $-1$  volt, since the delay voltage is  $+1$  volt,  $R_2$  and  $R_3$  will drop 1 volt so that the voltage at their junction, which is applied to the diode anode, is zero volts. The diode doesn't conduct, then, and there is zero AGC voltage. When the detector output is *less* than  $-1$  volt because a weak signal is being received, the junction of  $R_2$  and  $R_3$  tends to go positive. The diode conducts and *clamps* the junction to ground (clamping is covered later), so there is still zero AGC voltage.

As a matter of fact, this condition continues for any weak signal that causes less than  $-1$  volt at the detector. The diode conducts to prevent the AGC line from going positive as long as the negative output of the detector is *less* than the delaying voltage. Thus, the AGC is zero for all weak signals so that they can get maximum gain.

When a stronger signal is received, causing the negative detector output to be greater than the positive delay voltage, the voltage at the junction of  $R_2$  and  $R_3$  will be negative. The diode, then, will no longer conduct, and that negative voltage will be filtered by  $C_2$  and  $R_4$  and sent as the AGC voltage. The amplitude of the AGC will depend on how much greater the detector output is than the delay voltage.



# amplified AGC

The AGC circuits previously discussed are suitable when the changes in signal strength that must be compensated for are not too large. When the signal strength varies widely, though, the AGC voltage variation is too small to give *full compensation*. As a result, some variations in signal amplitude still exist at the output of the receiver.

To keep the receiver output constant even for large variations in signal strength, a larger AGC voltage variation must be developed than is possible with a basic AGC circuit. This can be done by using an *amplified AGC circuit*.

A typical amplified AGC circuit is shown. It uses a separate amplifier stage to increase the level of the detected signal. This AGC amplifier receives the rectified signal from the detector through capacitor  $C_1$ . Its amplified output is rectified by the AGC rectifier and filtered by resistor  $R_5$  and capacitor  $C_4$ . The resulting amplified AGC voltage is applied to the controlled stages along the AGC line. Variable emitter resistor  $R_3$  permits adjustment of the gain of the AGC amplifier. In this way, the AGC voltage can be set at any desired level. If an AGC delay network similar to that described on the previous page is added at the output of the AGC rectifier, the circuit will provide a delayed AGC. Variable resistor  $R_3$  then acts as a *threshold control*.

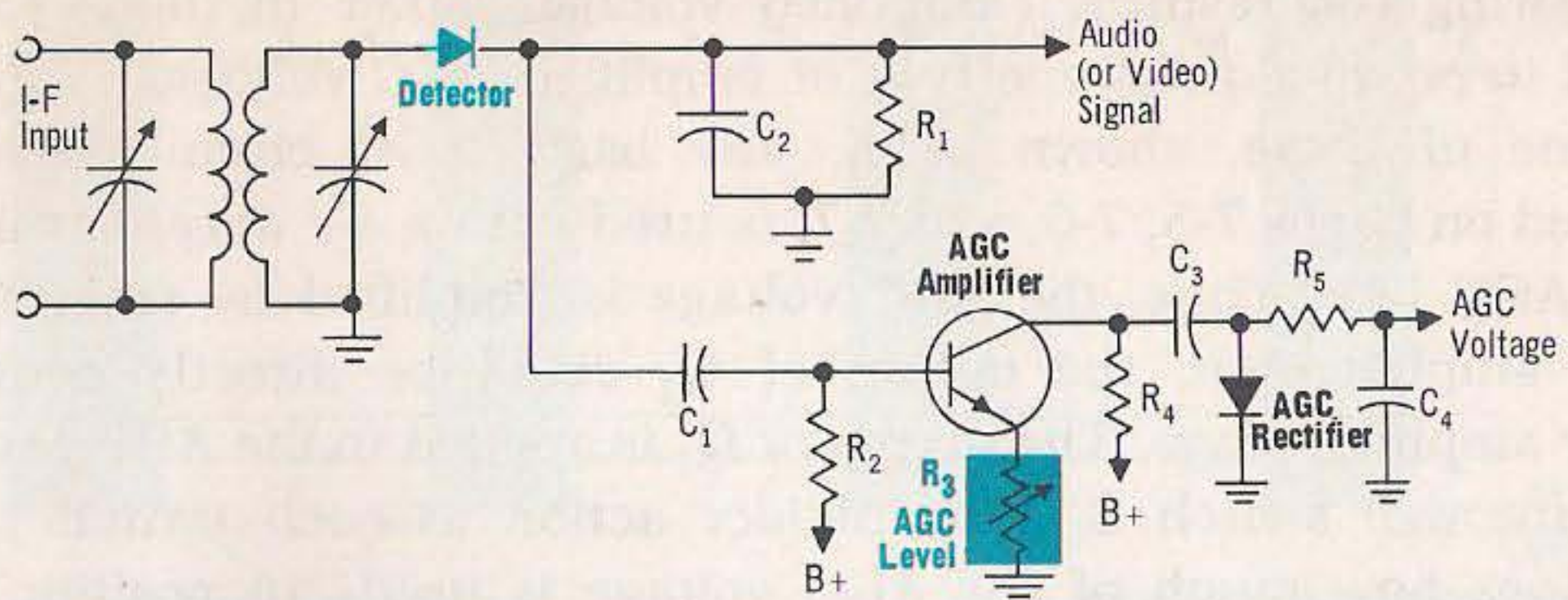

Essentially, an amplified AGC circuit contains an amplifier stage between the signal detector and the AGC rectifier and filter. An AGC level control sets the AGC action

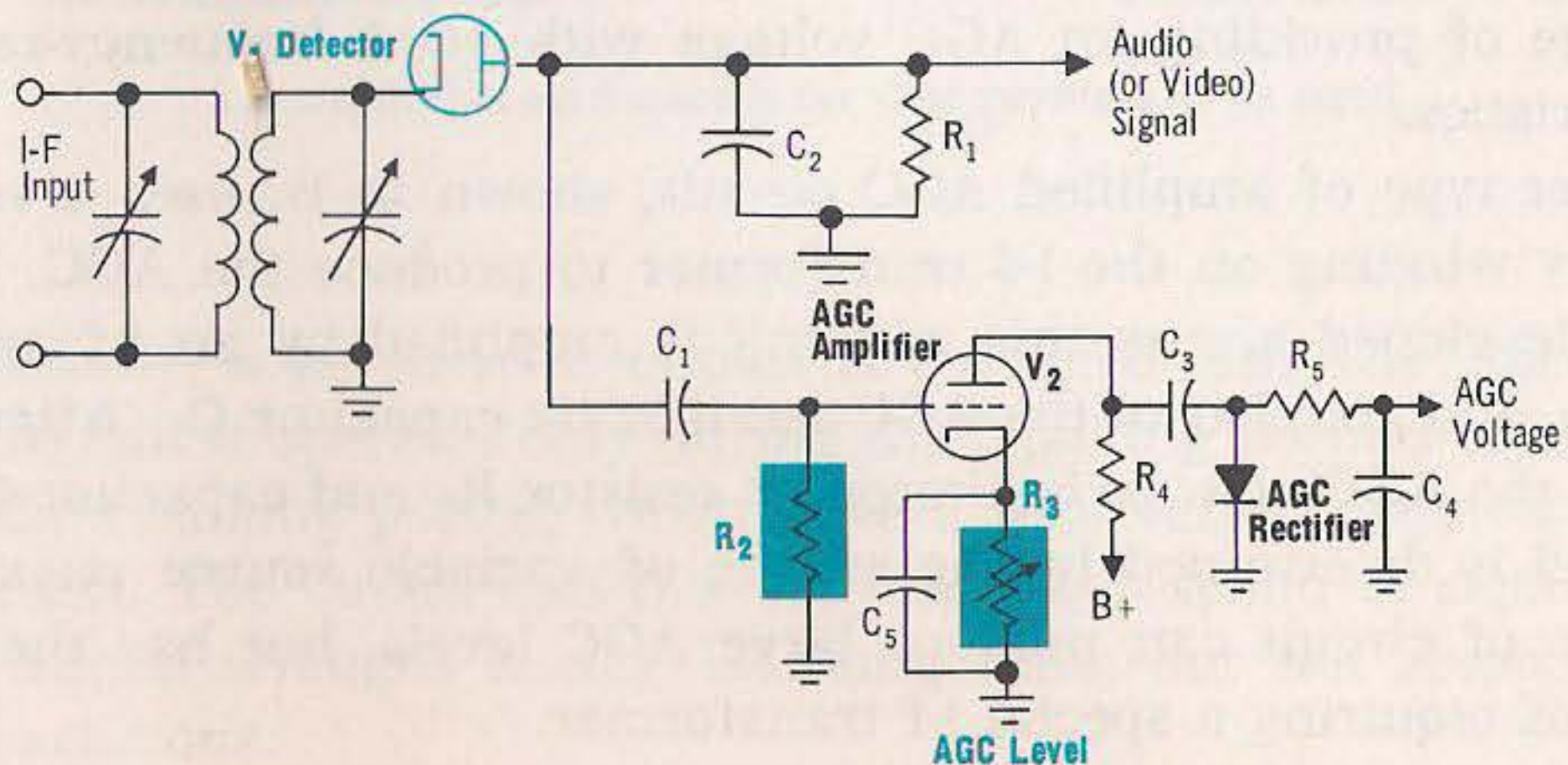

# Other amplified AGC circuits

Amplified AGC can be produced by first developing the AGC voltage and then d-c amplifying it...

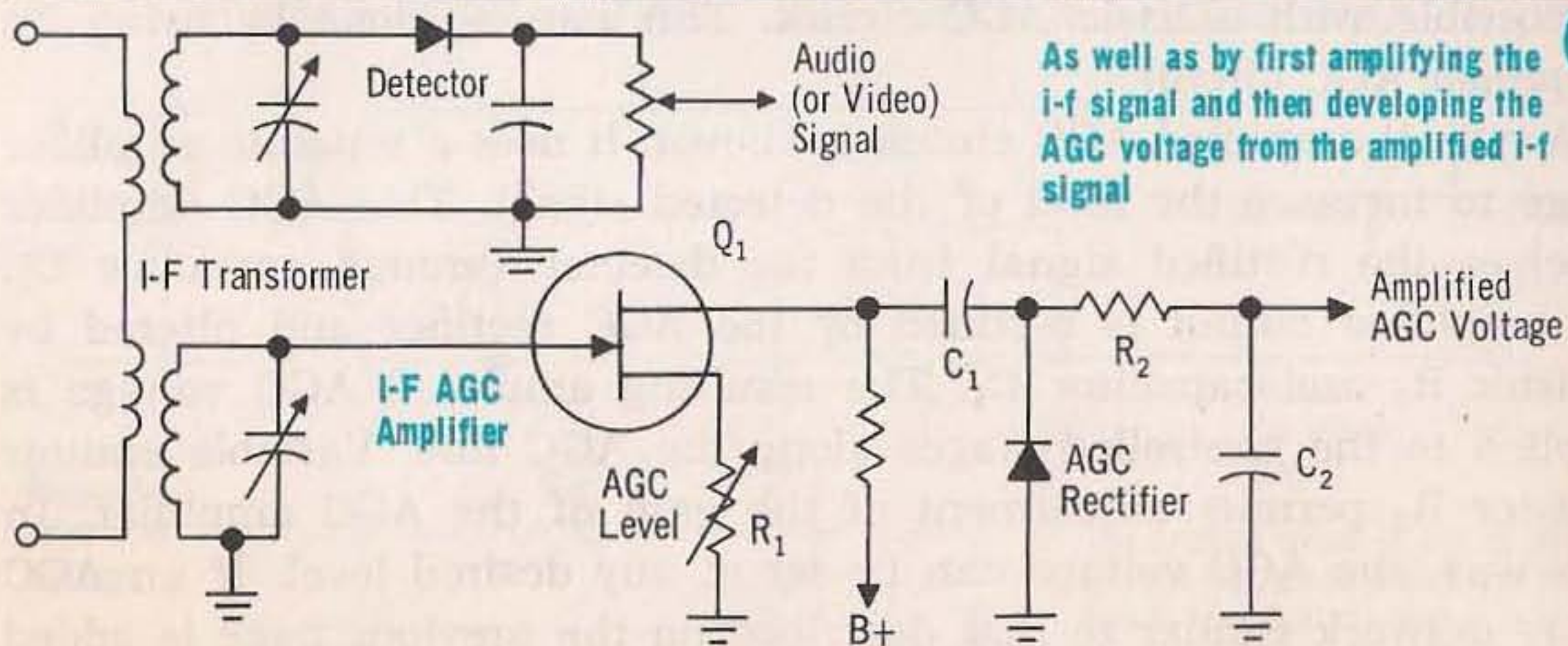
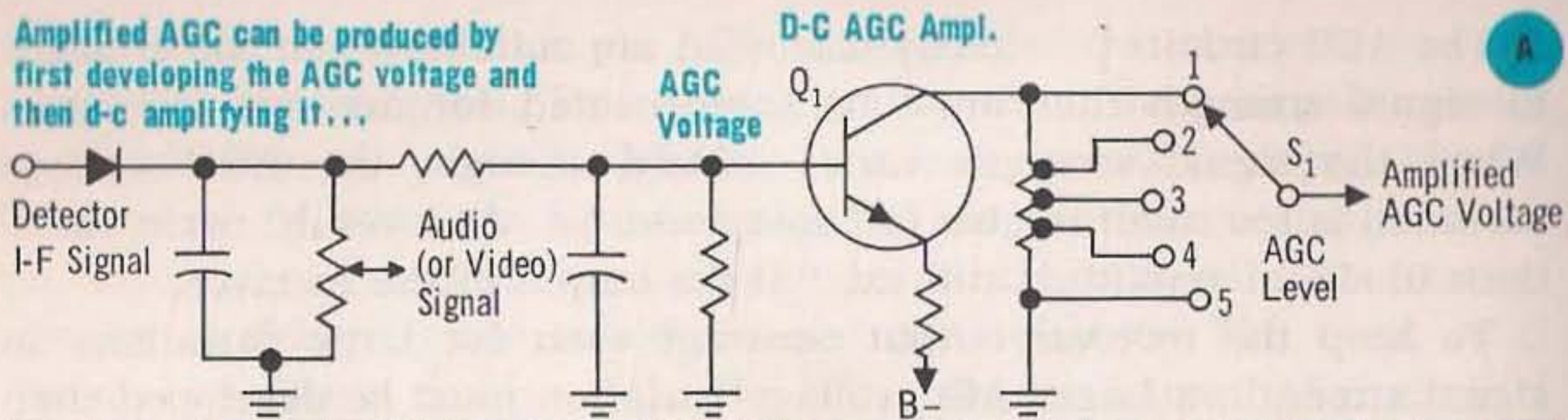

You have seen on the previous page how amplified AGC can be produced by amplifying a portion of the detector output and then rectifying and filtering the resulting amplified voltage. Other methods can also be used to produce the same type of amplified AGC voltage.

In one of these, shown in A, any basic AGC circuit, like those described on pages 7-5, 7-6, and 7-7, is used with a *d-c amplifier* inserted in the AGC line. Thus, the AGC voltage is amplified by stage Q<sub>1</sub>. For greater amplification, the output of Q<sub>1</sub> could be directly coupled to another amplifier stage. The output of Q<sub>1</sub> is applied to the AGC-controlled stages through switch S<sub>1</sub>. The divider action at each switch position determines how much of the AGC voltage is used: in position 1, the full AGC is used, in 5, the AGC is disabled, and the other positions provide different levels of AGC. This method of amplified AGC has the advantage of providing an AGC voltage with good frequency-response characteristics.

Another type of amplified AGC circuit, shown in B, uses a *separate* secondary winding on the i-f transformer to produce the AGC. The i-f voltage developed across this winding is amplified by an i-f amplifier stage, Q<sub>1</sub>, and coupled to the AGC rectifier by capacitor C<sub>1</sub>. After being rectified, the AGC voltage is filtered by resistor R<sub>2</sub> and capacitor C<sub>2</sub>. The AGC level is determined by the setting of variable source resistor R<sub>1</sub>. This type of circuit can produce large AGC levels, but has the disadvantage of requiring a special i-f transformer.

# keyed AGC

As explained previously, AGC circuits are designed so that they do not respond to amplitude variations that represent signal intelligence. This is done by making the RC time constant of the AGC filter circuit long in relation to the frequency of the signal variations. Ordinary AGC circuits are, therefore, relatively *slow acting* and cannot respond to rapid variations in signal strength.

In television receivers, the sluggishness required of the AGC circuit to keep it from responding to changes in the *average* level of the video signals would be particularly objectional. Therefore, AGC circuits are often used that can respond more rapidly to changes in signal strength, but at the same time do not respond to the average video levels of the picture signal. Such circuits are called *keyed*, and, sometimes, *gated*, AGC circuits.

A keyed AGC circuit operates only during the blanking portion of the composite television signal

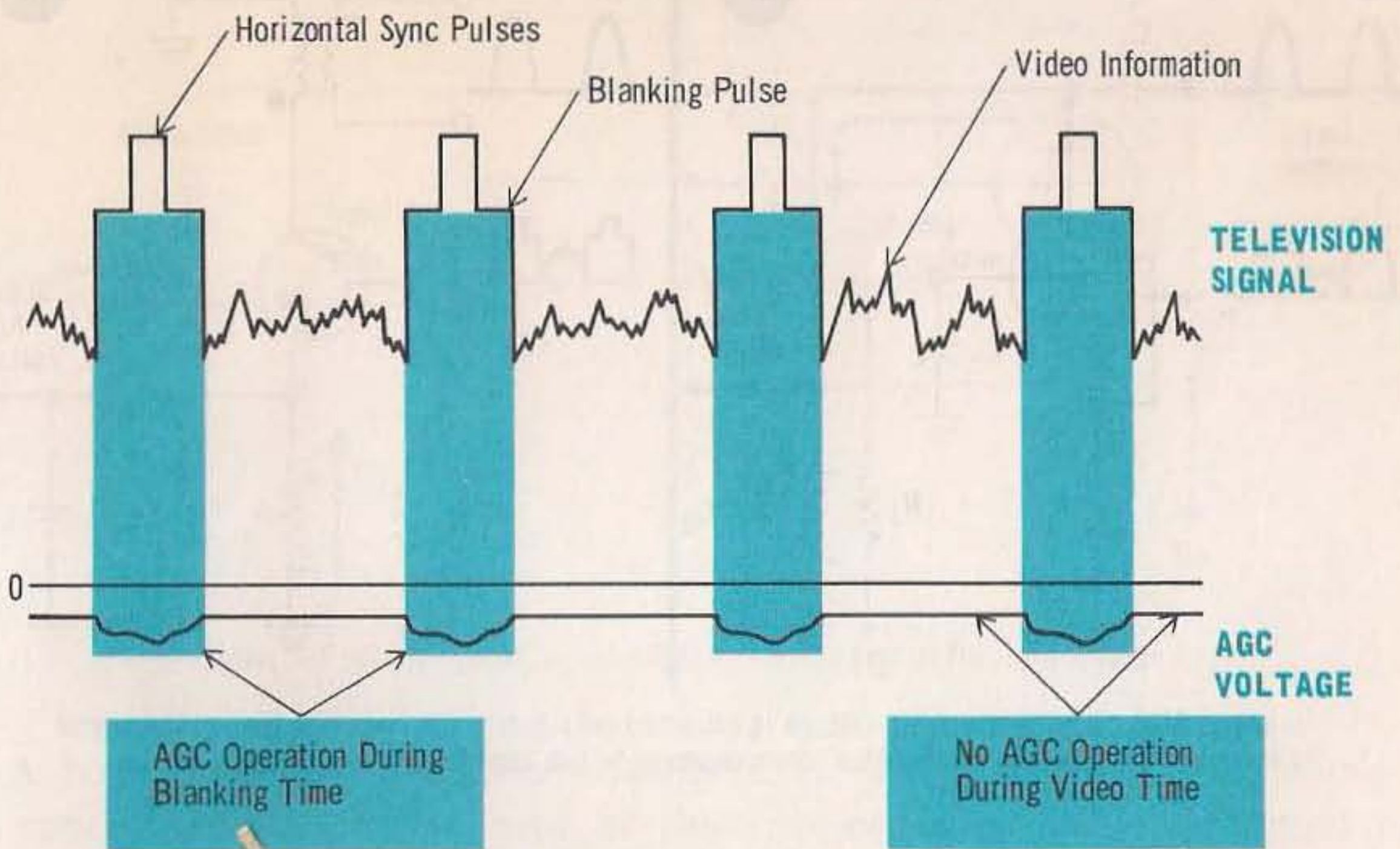

The circuit does not respond to the video variations of the signal

Essentially, a keyed AGC circuit is cut off during the video portion of the signal. It operates only during the blanking portion of the signal, when the blanking pulses, which have a relatively constant amplitude, are present. The circuit can thus be made to respond to rapid changes in the signal strength during blanking time, but not respond to the video variations.

# keyed AGC circuits

One type of keyed AGC circuit is shown in A. It consists of a pentode stage with the video signal applied to the control grid. Plate voltage for the stage is *capacitively* applied in the form of a keying signal, or voltage, derived from the horizontal flyback pulse produced by the scanning circuits. The tube can conduct only when the keying signal provides plate voltage. This occurs at the same time that the horizontal blanking pulses appear at the control grid. The net result is that the tube is cut off during the video portions of the composite signal and conducts during the blanking portions in an amount corresponding to the amplitude of the blanking pulse. The average negative voltage developed across plate load resistor  $R_3$  therefore varies in proportion to the blanking signal amplitude. This voltage is filtered by  $R_4$  and  $C_3$ , and a steady AGC voltage is produced.

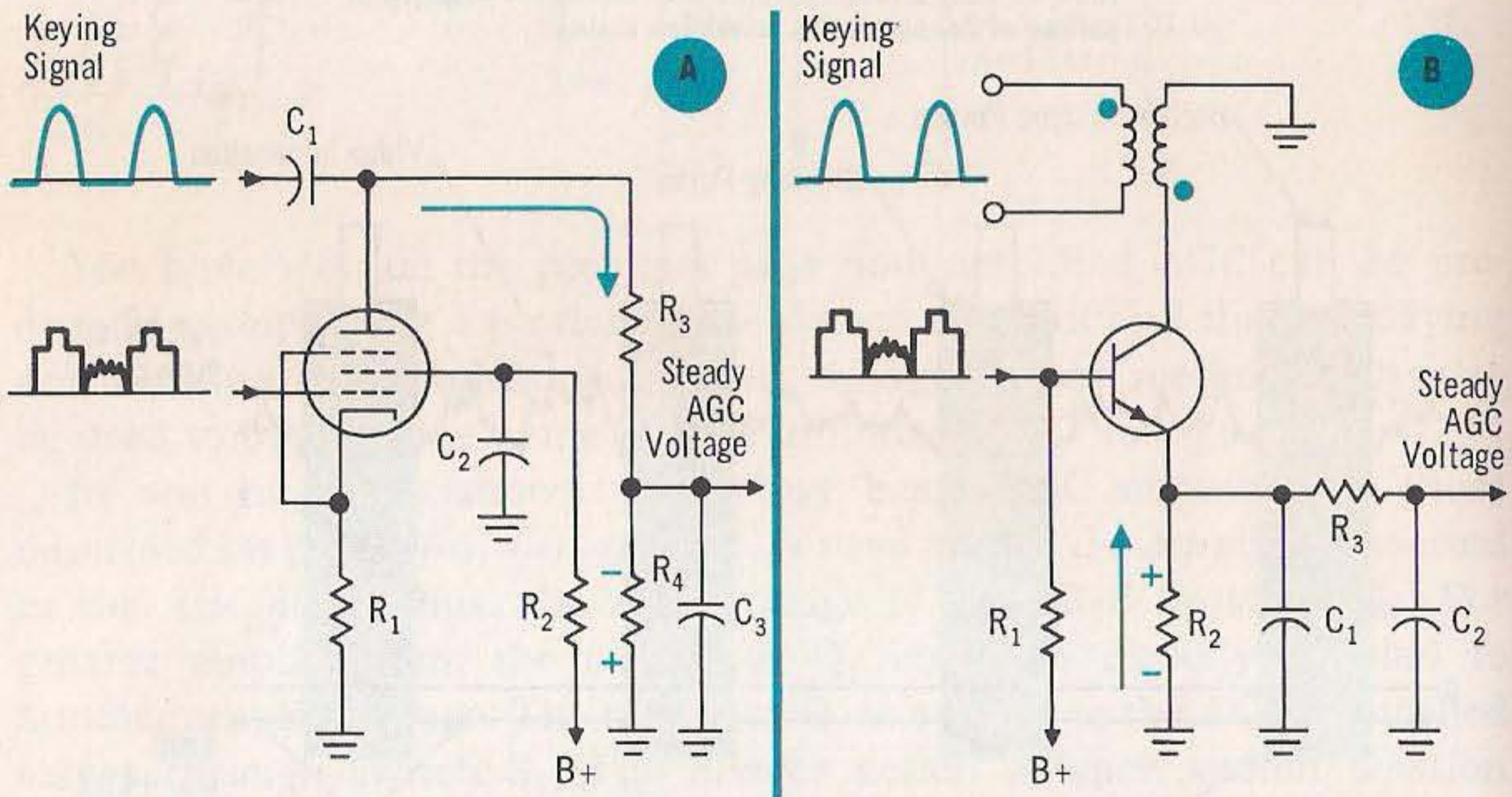

In keyed AGC circuits, the AGC voltage is produced only during the time that the keying signal is present. The average current that flows depends on the amplitude of the blanking pulse

Another type of keyed AGC circuit is shown in B. In this circuit, the keying signal is *inductively* coupled to the collector of the transistor. Except for the method of coupling the keying signal, the circuit operates essentially the same as that in A. Collector voltage is applied only when the keying signal is present. This coincides with the horizontal blanking pulses, so the stage only conducts during the horizontal blanking time. The stage operates as an emitter follower, with the AGC voltage developed across emitter resistor  $R_2$  during conduction. A positive AGC voltage is filtered by resistor  $R_3$  and capacitors  $C_1$  and  $C_2$  to provide a steady bias.

# quiet AGC (squelch) circuits

With AGC, a receiver's sensitivity is *maximum* when *no signal* is being received. This condition occurs, for example, when the receiver is being tuned between stations. Because of the maximum sensitivity, the *background noise* picked up by the antenna between stations is greatly amplified by the receiver. This can be highly annoying, especially in radio receivers where the amplified noise is heard in the loudspeaker. To overcome this problem, a circuit called a *quiet AGC* circuit, or *squelch* circuit, is often used. Such a circuit cuts off the receiver output when no input signal is being received. It does this by blocking either the detector or audio amplifier when no signal is present.

A

A squelch circuit, or quiet AGC circuit, is also sometimes called a muting circuit, since it cuts off, or mutes, a receiver when no input signal is being received

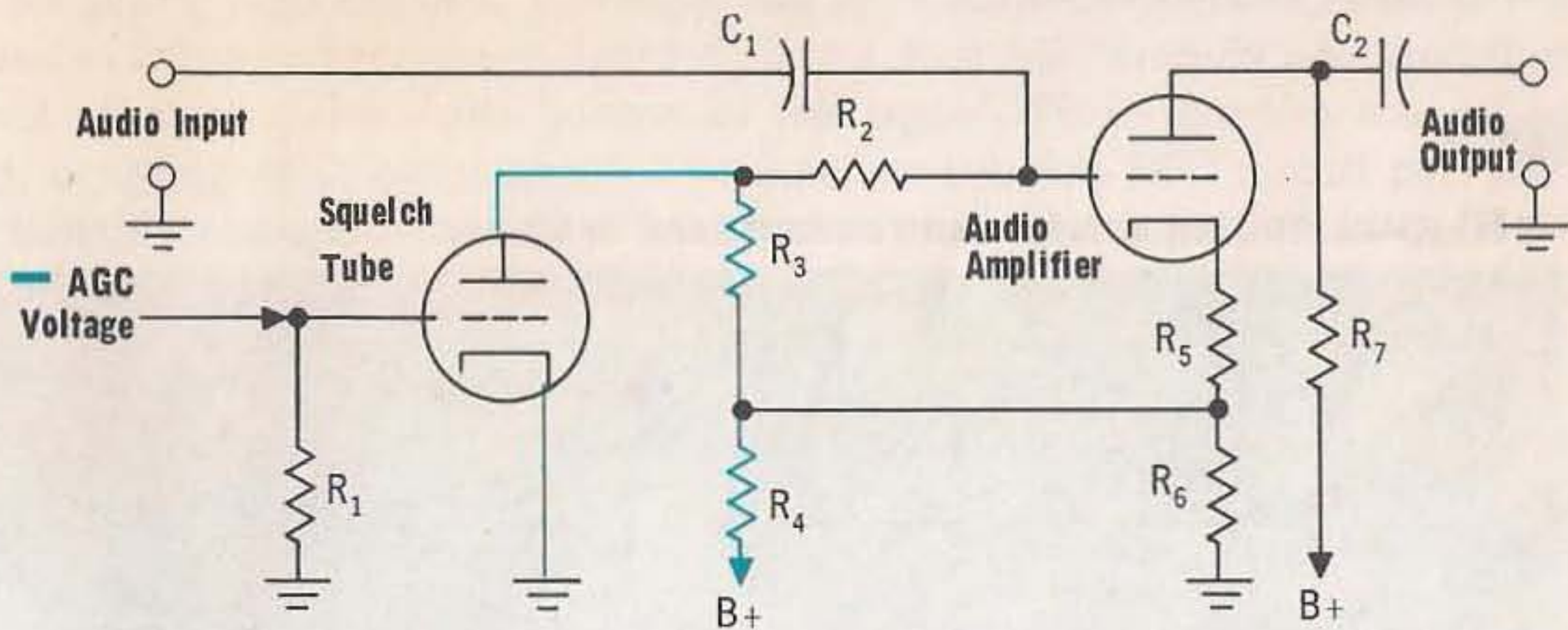

Here, the squelch circuit is activated by the absence of the AGC voltage

A basic squelch circuit is shown in A. The receiver AGC voltage is applied to the control grid of the squelch tube. When a signal is present at the receiver input, the AGC voltage it produces cuts off the squelch tube. The audio amplifier stage therefore operates normally, using cathode bias provided by resistors  $R_5$  and  $R_6$ . With no signal at the receiver input, the squelch tube conducts, since no AGC voltage is produced. The plate current of the squelch tube then flows through resistor  $R_3$ , which is in the grid circuit of the audio amplifier. This reduces the positive voltage a great deal at that point, and effectively places a large negative bias on the grid of the audio amplifier, cutting off the stage and preventing background noise from reaching the loudspeaker.

# quiet AGC

## (squelch) circuits (cont.)

As an example of the circuit's operation, assume that there is an AGC input that cuts off the squelch tube. The values of  $R_4$  and  $R_6$  are such that their divider action puts +10 volts at the top of  $R_6$ . But, since both the grid and cathode are returned to the same point, the +10 volts have no effect. However, in between stations, when there is no AGC, the squelch tube conducts heavily and the plate current through  $R_3$ , which has a large value, causes the junction at  $R_2$  and  $R_3$  to be almost at ground. Now, the grid is returned to ground, but the cathode has +10 volts on it. This cuts off the audio amplifier.

You might notice that this circuit could not work off a delayed AGC, since no AGC voltage would be produced for weak signals and the receiver would be disabled. But it would work if a separate circuit were used to produce a d-c voltage from a signal in the audio section. In this case, the squelch circuit would be independent of the AGC circuit. Such a circuit is shown in B.

B

The FET squelch circuit here works in a manner similar to that of the tube circuit

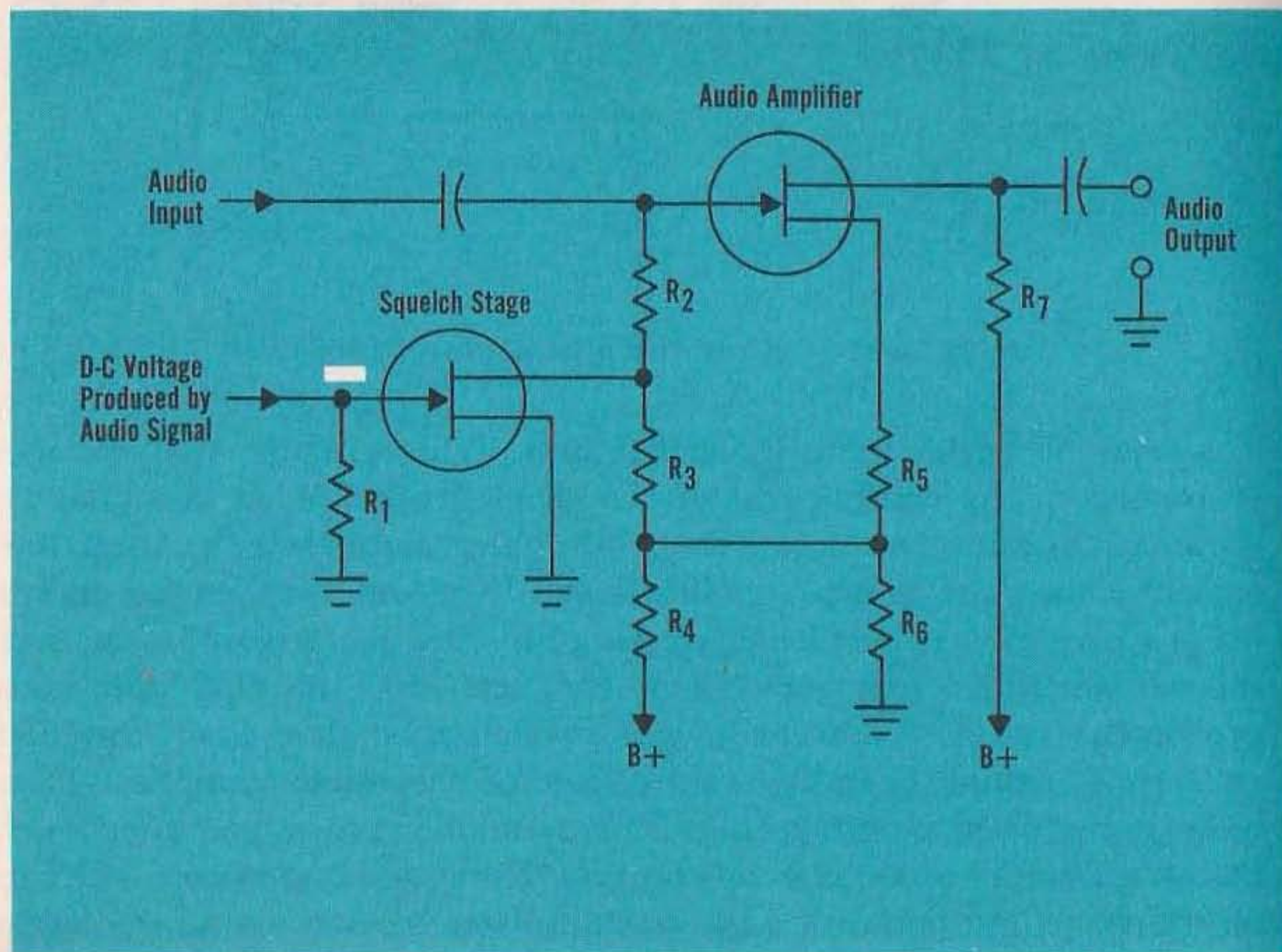

In between stations, when the negative voltage is not there, the squelch stage conducts heavily, putting the junction of  $R_2$  and  $R_3$  at a low voltage (near ground). This cuts off the audio amplifier